

Mounting instructions

novotegra for corrugated eternit/
sandwich – side-fix roof parallel

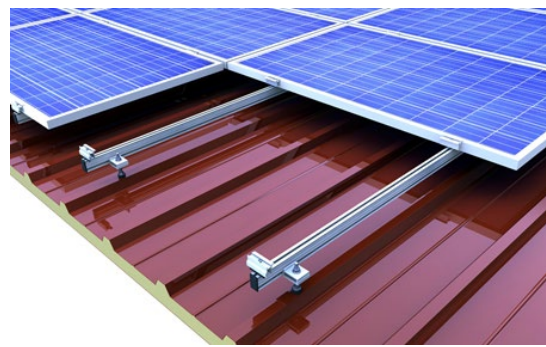
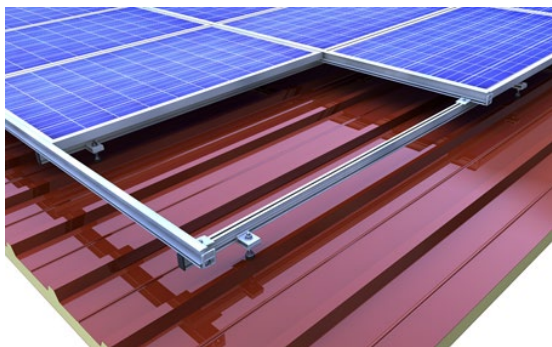
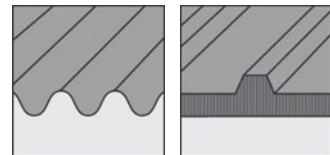

TABLE OF CONTENTS

1	Notes	1
2	Maintenance of the mounting system	3
3	novotegra for corrugated eternit/sandwich roofs	3
4	System components, tools and equipment	4
4.1	What is required for mounting	4
4.2	Mounting system components – mounting versions	5
4.3	Mounting system components – optional	6
5	Installing the mounting system	7
5.1	Stock screw mounting	7
5.2	Rail mounting	8
5.3	Module mounting	9
5.4	Mounting versions	11
6	Warranty / product liability (exclusion)	16

1 Notes

The following instructions are generally valid for our mounting system novotegra and are to be applied or interpreted accordingly regardless of the respective roof and mounting system type.

Safety information

Mounting tasks may only be carried out by qualified and competent persons. During the work protective clothing in accordance with the relevant national regulations and guidelines must be worn.

Mounting must be carried out by at least two persons to ensure help in case of an accident.

All relevant national and locally applicable health and safety regulations, accident prevention regulations, standards, construction standards and environmental protection regulations as well as all regulations of the employers' liability insurance associations must be complied with.

The national regulations for working at height / on the roof must be complied with.

Electrical work must be carried out in compliance with the national and locally applicable standards and guidelines and the safety rules for electrical work.

Earthing / equipotential bonding of the mounting system must be carried out in accordance with the national and locally applicable standards and guidelines.

Categorisation into hazard classes

To alert the user of potential danger situations the hazard classes analogous to ANSI Z 535 are used. The hazard class describes the risk if the safety information is not observed.

Warning symbol with signal word

Hazard class analogous to ANSI Z 535



DANGER! describes an immediate danger. If it is not avoided, death or serious injury will result.



WARNING! describes a potential danger. If it is not avoided, death or serious injury might result.



CAUTION! describes a potential danger. If it is not avoided, light or minor injury might result.



NOTE! describes a potentially harmful situation. If it is not avoided, the plant or objects in its vicinity might be damaged.

General information

After receipt the goods must be inspected for completeness using the accompanying delivery note.

BayWa r.e. Solar Energy Systems GmbH does not accept the costs, nor can we guarantee subsequent express deliveries if missing material is only noticed during mounting.

Since our mounting systems are subject to continuous development, mounting processes or components may change. Therefore, please check the current status of the mounting instructions on our website prior to mounting. We are also happy to send you current versions upon request.

The mounting system is suitable for the attachment of PV modules with standard market dimensions. Please find more detailed information about this in chapter 3.

The usability of the mounting system for the respective project must be checked for each individual case on the basis of the roof cover / roof construction / facade present.

The roof cover / roof construction / facade must meet the requirements of the mounting system with regard to load bearing capacity, support structure and condition.

Requirements for the material of the roof construction / roof cover / facade:

Wooden components (rafters/purlins): min. strength class C24, no fungus infection or rot

Tensile strength R_m , min for trapezoidal metal: steel 360 N/mm²; aluminium 195 N/mm²

Wall construction material: concrete, brick or sand-lime brick in solid or hollow block design.

The load bearing capacity of the roof / roof construction (rafters, purlins, trapezoidal metal, concrete floors, number of adhesive points, folded seams, etc.) or the facade (wall construction materials) must be checked by the user or a check be commissioned.

Physical building aspects concerning insulation penetrations (e.g. condensation) must be taken into account by the user.

Notes on mounting

The components of the novotegra mounting system are intended exclusively for the attachment of PV modules. Dependent on the roof type of the building the designated mounting system components must be used.

A condition for the intended use of the novotegra mounting system is the mandatory compliance with the specifications in these instructions regarding safety information and mounting.

In case of unintended use and non-compliance with the safety information and mounting instructions and non-utilisation of the corresponding mounting components or use of third party components not belonging to the mounting system any warranty and liability claims against the manufacturer are voided. The user is liable for damage and resulting consequential damage to other components, such as PV modules, or the building as well as personal injury.

The user must read the mounting instructions prior to mounting. Unresolved issues must be clarified with the manufacturer prior to mounting. The mounting sequence in these instructions must be adhered to.

It must be ensured that a copy of the mounting instructions is accessible in the immediate vicinity of the work on site.

The mounting specifications (module load, attachment, clamping areas etc.) of the module manufacturer must be observed and complied with.

Prior to mounting the mounting system must be statically calculated with the loads to be assumed for the building project in accordance with the national standards. Information relevant to mounting (e.g. roof hook distance, lengths of bolts, overhang and protrusions or distance of base trough and required ballast) must be determined by the static calculation using the design software www.solar-planit.

The permissible roof inclination for using the mounting system according to these installation instructions is 0 to 60 degrees for roof-parallel installation on a pitched roof and 0 to 5 degrees for elevated installation on a flat roof. Facade systems must be mounted parallel to the facade.

For roof-parallel installation with the clamping system, two module support rails per module must be mounted symmetrically under the modules for equal load transfer into the substructure. Alternatively, the roof-parallel installation can also be installed with insertion rails.

The specified tightening torques must be adhered to and checked randomly on site.

Notes on static calculations

The mounting system must generally be statically calculated for each individual project using the design software Solar-Planit. Excluding façade systems, the calculation for this will be carried out by the company BayWa r.e. Solar Energy Systems GmbH.

The static calculation only determines the load bearing capacity of the novotegra mounting system and also takes account of the attachment to the building (rafters, purlins, trapezoidal metal, facade etc.). The load transfer within the building is not considered (customer static calculations).

The load bearing capacity of the mounting system components is determined on basis of the planned module layout and the underlying building information (project data recording). Deviations from the planning on site may lead to different results.

The load assumptions (load and roof division) are country-specific in accordance with the specifications of the Eurocode load standards. The determination of the loads to be assumed for Switzerland is in accordance with SIA 261.

At pitched roof, the modules may not be fitted above the gable end, ridge and eaves or the facade (increased wind load). At the ridge the modules may be fitted up to max. a theoretical horizontal line with the ridge tile and perfectly flush with the gable end. In the eaves area the modules may reach to max. the end of the roof cover due to loads.

In case of an exposed building position (with wind load e.g. at the edge of a slope) or snow accumulation (e.g. dormer or catchment grill or roof structures like domelights etc) the specifications of the Eurocode load standards or SIA 261 (Switzerland) must be taken into account by the user within his own responsibility. The design software does not consider these cases.

The static calculation of the mounting system is based on the symmetrical placement of the modules on the mounting rails at the longitudinal side of the modules (roof-parallel clamping systems) or on the support components (elevation) for equal load transfer into the substructure. For the insertion system a cross rail arrangement is expected for equal load transfer.

The results calculated with the design software, such as distances of the fasteners (e.g. roof hooks, stock screws, saddle clamps etc.), rail lengths and number of fasteners (e.g. direct attachment on the trapezoidal metal), overhang (e.g. rail and roof hook protrusions) or distances between the base troughs and number of fixing materials (e.g. rail joint) and the other calculation notes must be considered and complied with.

novotegra has been tested and certified by TÜV Rheinland:



2 Maintenance of the mounting system

The mounting system must be checked for stability and operation at regular intervals during the system maintenance.

In addition to the visual inspection of the components, we recommend a random check of the connections and the safe and correct position of the ballast on the base rails and ballast troughs.

Removal is possible in reverse order in the work steps mentioned below.

The maintenance work must be carried out by a specialist company with proven experience in electrical systems and work on mounting systems.

3 novotegra for corrugated eternit/sandwich roofs

The content of these mounting instructions describes the design of the mounting system on roofs with corrugated eternit, corrugated and trapezoidal metal and sandwich profiles. In connection with metal shingles stock screws can also be used e.g. on shingle roofs. The maximum permissible module width is 1.34 m for the respective mounting system to be used.





For the mounting of photovoltaic systems on roof covers containing asbestos the corresponding guidelines for health and safety regulations must be complied with.

4 System components, tools and equipment

4.1 What is required for mounting

Figure	Tool	Component*	Product group
		Stock screw GPS1 (for wood) Material: stainless steel Tool: Socket AF 7 or 9	Roof attachment
		N-rail Material: Aluminium	Profile rails
		Rail connector set N Material: Aluminium and stainless steel Tool: Socket AF 8	Rail connectors and expansion joint
		End cap N-rail Material: PA	Module protection and rail top cover
Insertion system			
		Insertion rail Material: Aluminium	Profile rails
		Rail Connector set IR Material: Aluminium and stainless steel Tool: Hexagon socket AF 3	Rail connectors and expansion joint
		Cross rail connector set N IR M8 Material: Aluminium and stainless steel Tool: Socket AF 13	Rail connectors and expansion joint
		Edge stop set IR Material: Aluminium and stainless steel Tool: Torx TX bit 30	Module protection and rail top cover

* The components vary dependent on the roof requirements, the static calculation or the component selection and may differ from the figures above.

Figure	Equipment	Use for tools	Application
	Battery-operated screwdriver	Torx bit or AW drive Socket AF 8	Clamp mounting component attachments
	Torque spanner up to min. 50 Nm	Special socket AF 18 deep or socket AF 13	Rail assembly
	Torque spanner up to min. 10 Nm	Socket AF 8	Clamp assembly
	Mitre saw	---	Rail section
	Spiral drill bit	Drill bit diameter (mm): 6.8; 7.0; 7.2; 7.4; 7.5; 9.0; 14.0; 16.0	Drill or predrill roof construction

4.2 Mounting system components – mounting versions

Figure	Tool	Component**	Product group
		Metal shingle Material: Aluminium	Accessories and optional components
		Base plate Alu for stock screw Material: Aluminium	Accessories and optional components
		Stock screw bridge Material: Aluminium and stainless steel Tool: Special socket AF 18 deep	Roof attachment
		Cross rail connector set NC M8 Material: Aluminium and stainless steel Tool: Socket AF 13	Module protection and rail top cover

Insertion system









Figure	Tool	Component**	Product group
		Support rail IR Material: Aluminium	Profile rails
		Insertion Rail Plus Material: Aluminium	Profile rails
		EPDM-T protection IR Material: EPDM	Module protection and rail top cover





Figure	Tool	Component**	Product group
		Mounting set snowguard IR Material: Aluminium and stainless steel Tool: Socket AF 8	Accessories and optional components
		Snowguard IR 20 x 5 Alu round pipe Material: Aluminium	Profile rails
		Edge stop set IR Plus Material: Aluminium and stainless steel Tool: Torx TX bit 30	Module protection and rail top cover

Clamping system

		Cross rail connector set N Material: Aluminium and stainless steel Tool: Socket AF 13	Rail connectors and expansion joint
		Middle clamp sets N Material: Aluminium and stainless steel Tool: AW30 drive	Module attachment
		End clamp sets N and spacer Material: PA 6.6, aluminium and stainless steel Tool: AW30 drive	Module attachment
		Module slip guard set Material: stainless steel	Module protection and rail top cover

** Required components dependent on the substructure (e.g. cross rail arrangement), module attachment (e.g. clamping system) or module layout (e.g. transverse module mounting).

4.3 Mounting system components – optional

Figure	Tool	Component***	Product group
		End cap N-rail Material: PA	Rail top cover
		Cable collector N-rail PA 4 cables Material: PA	Cable fixing
		Cable-tie clip for profile flange	Cable fixing
		Cable clip d = 10 mm	Cable fixing

*** Optionally available mounting system components e.g. for the visual enhancement of the system or cable laying

5 Installing the mounting system

Prior to mounting, the module field on the roof must be measured and the position of the fasteners (e.g. roof hooks, stock screws, saddle clamps etc.) defined taking into account the static calculation.

The individual mounting steps are described below for mounting modules in portrait in the insertion system for corrugated cement fibre roofs. The mounting steps can be applied correspondingly to the installation on other roof types. Additional mounting versions (MV) for the various design options (e.g. clamping system or cross rail mounting) are described in the chapter "Mounting versions".

5.1 Stock screw mounting

Determining the position of the mounting rail

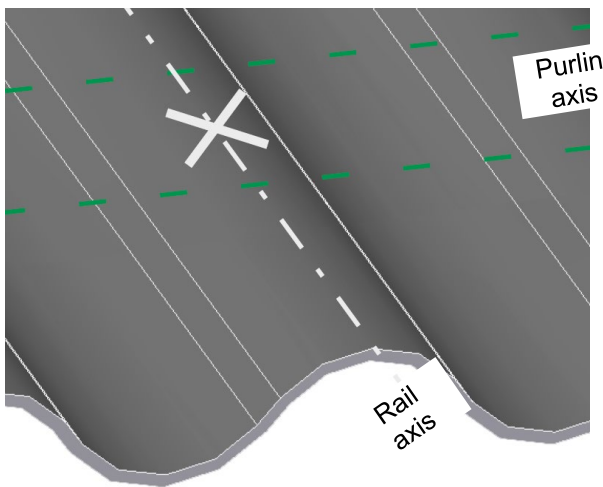

Draw the axis of the mounting rails on the corrugated crests / raised beads.

Mark the position of the stock screws along the rail axes above the purlins.

For steel purlin constructions note MV 1

⚠ WARNING

To execute the work a scaffold must have been installed in accordance with the relevant specifications.

Observe accident prevention regulations, prevent material damage.

Remove drilling residue.

Mounting the stock screw

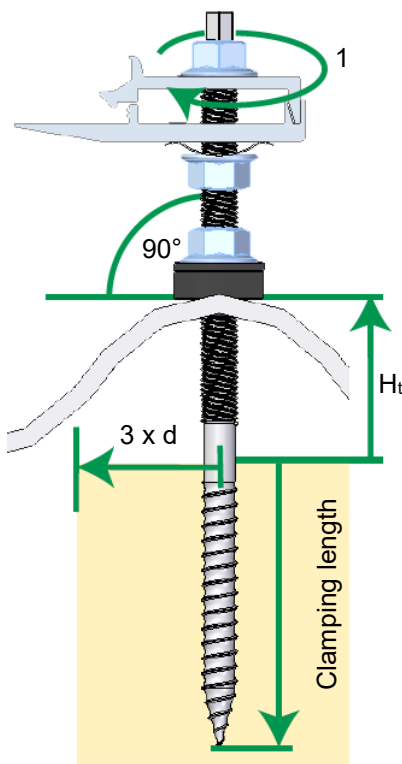

Predrill the wooden purlins through the roof cover, then drill out the roof cover, screw the pre fitted hanger screw vertically into the purlin, align the clamping device along the progression of the mounting rails (1). For mounting the stock screw bridges see MV 4.

Stock screw set:	M10	M12
Distance to the purlin edge:	30 mm	36 mm
Predrilling of wooden purlin:	7.5 mm	9 mm
Drilling out of roof skin:	14 mm	16 mm
Clamping length:	>40 mm	>60 mm

NOTICE

Stock screw length dependent on the height of the roof cover.

Height of cover H_t *	Stock screw length
up to 60 mm	200 mm
61 – 110 mm	250 mm
111 – 160 mm	300 mm

*for clamping length 80 mm

Correct fit of EPDM seal

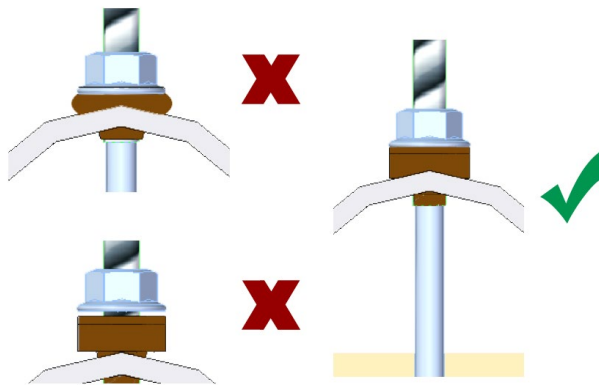

Tighten the lower self-locking nut until the EPDM seal is slightly compressed – the seal cone enters the predrilled hole of the roof cover.

⚠ WARNING

Sealing properties require the stock screws to be screwed in vertically.

5.2 Rail mounting

Mounting the rail

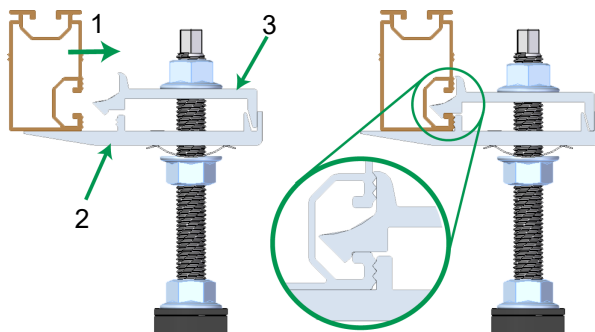

Place the rail onto the base profile and move it against the stock screw (1)

Only attach the rail track at one end, connect the rails to each other with the rail connector, only then attach the rails to additional stock screws.

NOTICE

The mounting rail is engaged in the clamping device when a “click” sound can be heard.

⚠ WARNING

Check the connection between the base profile (2) and the clamping profile (3).

Connect the rail

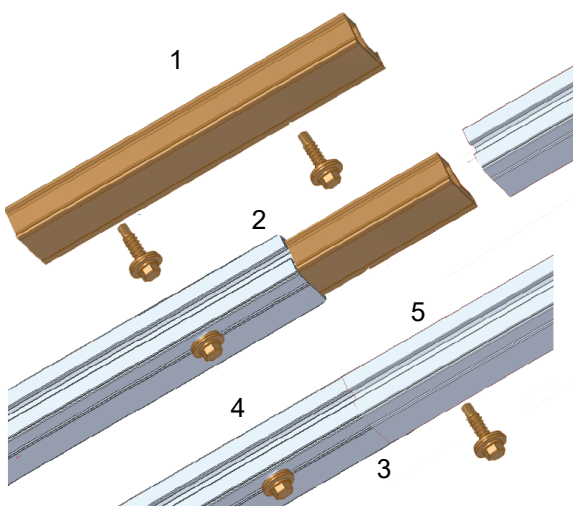

Push the connector (1) half way into one of the rails to be connected (2) and secure it there with a drilling screw in the lateral drilling groove. Then push the other rail completely onto the connector until both rail ends touch (3) and secure with a drilling screw, maximum rail length without interruption 8.5 m, then install an expansion joint.

N-rail L connector:

secure additionally with two drilling screws at the corresponding points (4 and 5).

⚠ WARNING

The accident prevention regulations must be complied with when cutting to size.

Securing the clamping device

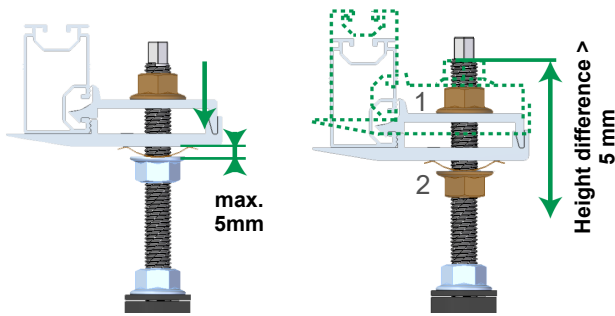

To compensate large height differences, move the bottom and top nut in the same direction (1 and 2), tighten the clamping device via the top nut, height corrections up to 5 mm are possible whilst clamped.

NOTICE

Clamping device tightening torque: 25 Nm.
The upper self-locking nut must sit fully within the thread area of the stock screw.
Finally, check the correct fit of the clamping profile.

5.3 Module mounting

Mounting the Cross rail connector IR

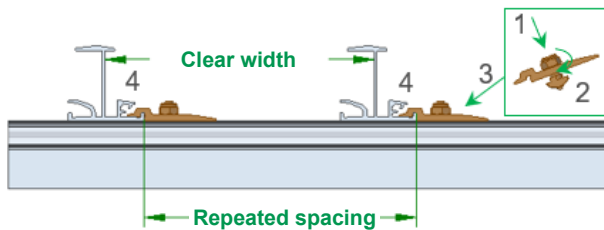

Insert the fixing clamp of the insertion rail from the top into the rail groove (1), rotate the nut by 90° (2) and push the component against the insertion rail (3) until the fixing clamp engages with the mounting flange (4).

For clamping system module mounting see MV 8.

NOTICE

Fixing clamp M8 tightening torque 25 Nm
Repeated spacing = module length L + 12 mm
Clear rail width = module length L + 10 mm
For mounting modules in landscape the module width must be used instead of the module length.

Position of the Cross rail connector IR

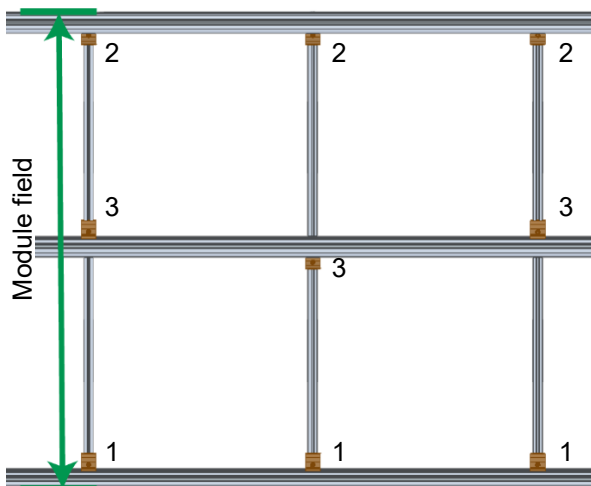

For the top and bottom insertion rail of the module field the Cross rail connector set N IR M8 is fitted on the inside in each case (1, 2), at the centre insertion rails the fixing clamps must be fitted alternating at the top and the bottom at the mounting flange (3).

NOTICE

Module field length =
Repeated spacing x number of module fields
+ width of insertion rail

Mounting Rail connector IR

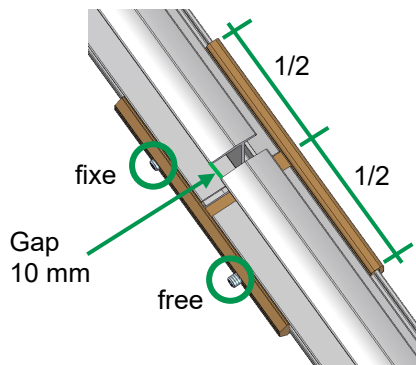

Centre the rail connector over the fitted rail and tighten the first threaded pin. Insert the rail to be connected into the connector, gap between the rails 10 mm, tighten the second threaded pin without play. MV 6 must be complied with for the mounting of the Insertion Rail Plus.

NOTICE

Do not fit connectors at the cantilever and above the drop rail.
Threaded pin without play for longitudinal expansion.

Module mounting: insertion system

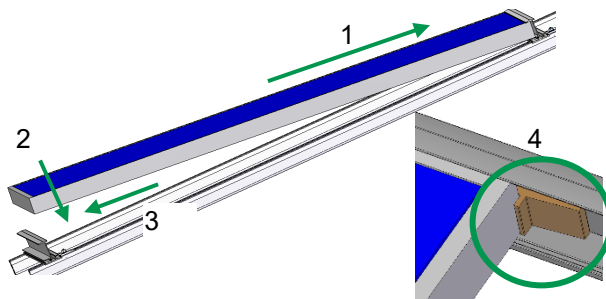

Place the module onto the top insertion rail and push it up (1), then lower the module onto the bottom insertion rail (2) and push it down against the insertion rail (3), mount the next modules following the same principle, the gap between the modules must be min. 3 mm.

NOTICE

Install the EPDM-T protection IR between the modules (4) with a module inclination <math>< 10^\circ</math> or as theft protection.

Edge stop mounting

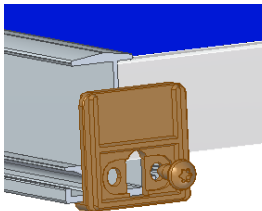

End cap for N-rail

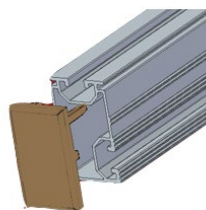

Fit an edge stop at the end of a module row at each insertion rail with a metal screw in the screw channel.

Seal the top and bottom ends of the N-rails with end caps.

NOTICE

The opening of the edge stop must expose the drainage channel of the insertion rail.

5.4 Mounting versions

MV 1 Stock screw – for steel purlin

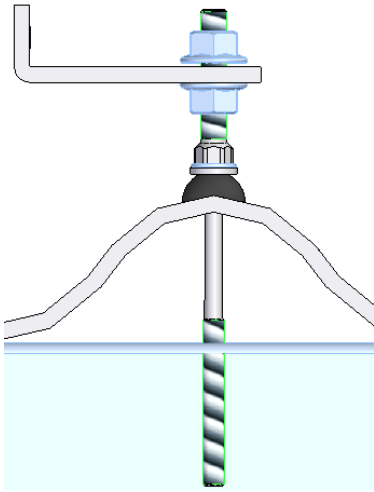

Stock screw set:	M10			
Predrilling the steel purlin	dependent on the material strength of the steel purlin			
Material strength (mm):	1.5<5	5<8	8<10	≥ 10
Predrilling the steel purlin:	6.8	7.0	7.2	7.4
Drilling out of roof skin:	not required			

NOTICE

For steel stock screws use EPDM round seal d = 25 mm

Height of cover Hat	Stock screw length
up to 60 mm	140 mm
61 – 105 mm	185 mm
95 – 140 mm	220 mm
141 – 180 mm	260 mm

MV 2 Shingle roof

MV 2.1 – Positioning the metal shingle

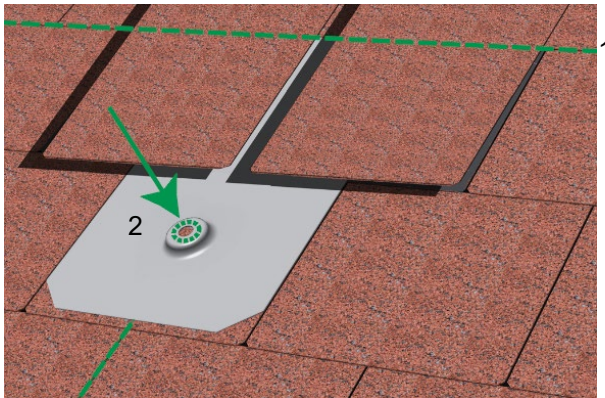

If necessary detach the shingle above, push the metal shingle flush up to the top edge of the roof shingle row below (1) and align, then mark the position of the stock screw (2) through the hole (d = 14 mm) in the metal shingle and predrill the rafters through the roof cover in accordance with the stock screw size (MV 1).

MV 2.2 – Attaching the stock screw and metal shingle

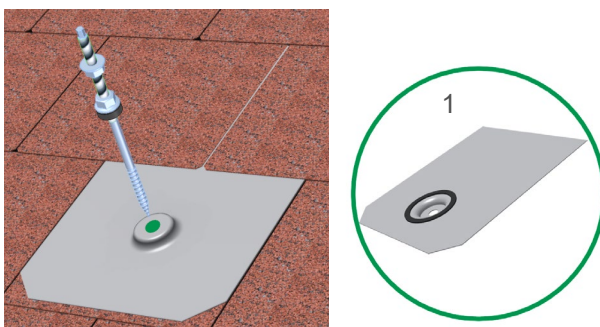

Position the projection of the metal shingle above the drill hole and screw in the stock screw.

When using the stock screw set M12 the drill hole in the metal shingle must be drilled out to 16 mm.

NOTICE

The prefitted seal at the bottom of the metal shingle (1) must adhere securely and tight.

MV 3 Connecting the mounting rail to the base plate

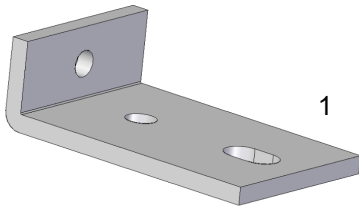

Place the base plates onto the lower self-locking nut and tighten finger-tight with the top self-locking nut, align the rail on the base plates by positioning the self-locking nuts accordingly, then tighten the top self-locking nut.

NOTICE

Self-locking nut tightening torque 50 Nm

MV 4 Connecting the mounting rail to the stock screw bridge

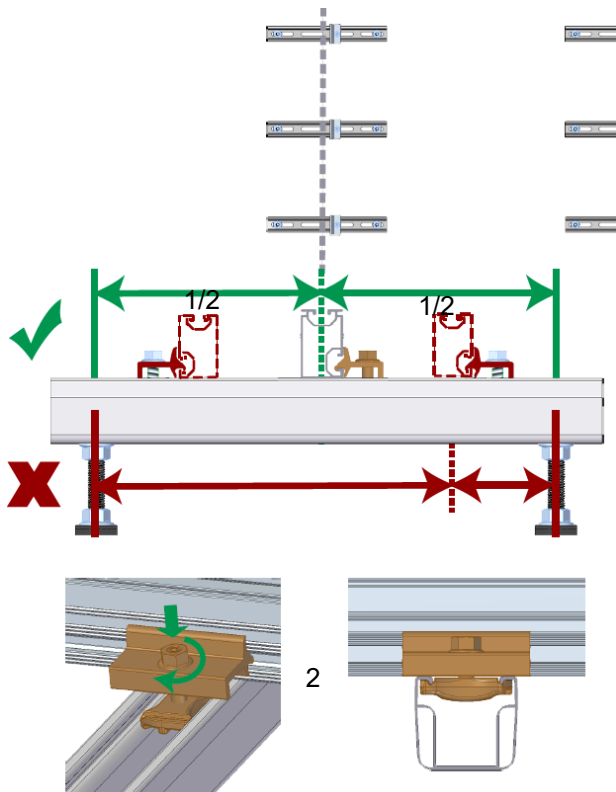

Fit the stock screws as described, carry out the height adjustment by positioning the nut. Position the mounting rails centred (1) on the bottom and top stock screw bridge of a rail axis, manually tighten the nut of the stock screw bridge and Cross rail connector set NC M8 (2), carry out the height adjustment for the other stock screw bridges. Then tighten all connections.

NOTICE

Cross rail connector set NC M8 torque: 25 Nm
Self-locking nut tightening torque 50 Nm.

WARNING

Check the correct fit of the rail nut and clamping part in the groove channel.

MV 5 Mounting Cross rail connector

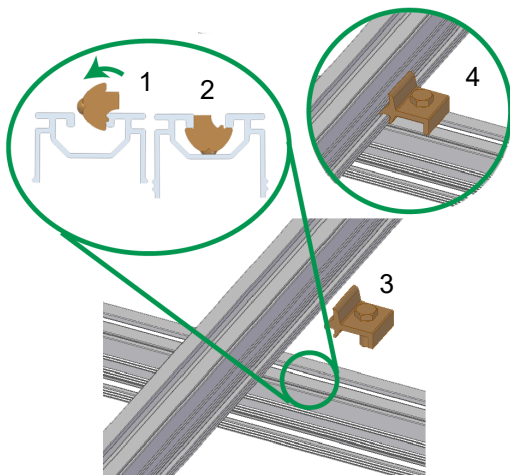

Insert the slot nut into the rail groove (1 and 2), attach the fixing clamp with the screw (3) to the slot nut and push it against the upper rail (4) until the Cross rail connector set N M8 with the mounting flange.

The module attachment with the clamping system is described in MV 8.

NOTICE

Cross rail connector set N M8 tightening torque 22 Nm.
Always attach to the side facing down.

MV 6 Heavy snow loads

MV 6.1 Insertion Rail Plus mounting

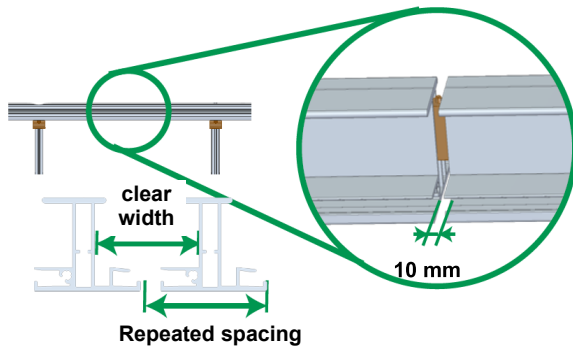

Attach the insertion Rail Plus to the N-rails with Cross rail connector set N IR M8 as the insertion rail, insert the connector for Insertion Rail Plus up to the stop and push the second rail with a distance of 10 mm over the rail connector.

NOTICE

Repeated spacing = module length L + 22 mm
Clear rail width = module length L + 10 mm

MV 6.2 Mounting the support rail IR

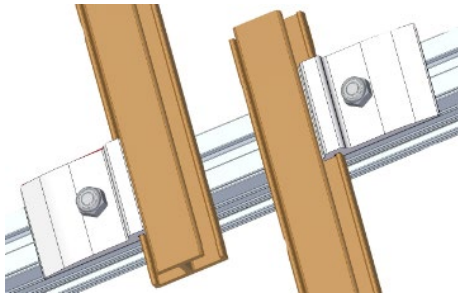

Attach the support rail IR with the cross rail connector set N IR M8, the support rails must be fitted parallel to the insertion rails and must be offset on the N-rail in the overlap area.

NOTICE

A 6.0 m long support rail must be attached with min. 3 Cross rail connector sets N IR M8.

MV 6.3 Distributing the round snow guard pipes

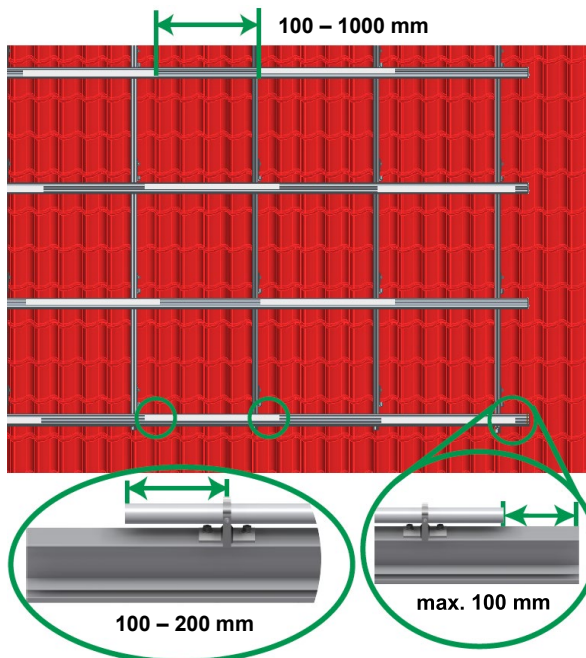

Distance between Aluminium round pipes at the end of the insertion rail in the corner area of the system max. 100mm.

Distance between round pipes min. 100 mm and max. 1000mm.

For each 800mm round pipe at least two brackets must be mounted at a distance of 100 – 200mm from the end of the pipe.

The same mounting instructions apply to 6.0m round pipes. Mounting distance of the brackets here is 500 – 600mm each.

NOTICE

Arrange snow stop ES 20 x 5 aluminium round pipes per row of rails in a staggered arrangement, observing the minimum and maximum distances.

MV 6.4 Attaching the bracket and mounting the edge stop

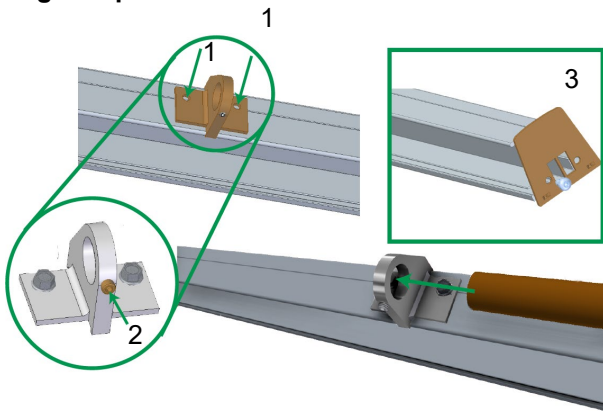

The brackets must be fitted with two drilling screws (1) to the insertion rail Plus. Position the rounded pipes centred and secure them with the grub screw (2).

Fit an end cap on the screw channel as edge stop at the end of a module row at each insertion rail with a metal screw (3).

NOTICE

If rounded pipes pass over a rail joint, only tighten one grub screw.
The openings of the edge stop must expose the drainage channels of the insertion rail.

MV 7 Slip guard portrait mounting

MV 7.1 Modules with frame holes

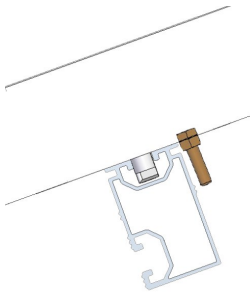

Prior to mounting the modules, the slip guards must be fitted to the frame holes above the top and bottom rail position.

MV 7.2 Modules with box frame

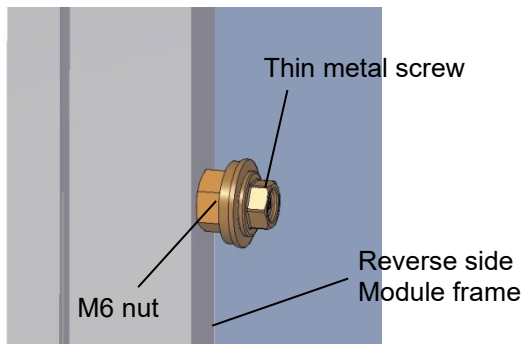

Push the nut over the screw and screw the thin metal screw without predrilling into the module frame.

NOTICE

The thin metal screw must not be overtightened.

MV 8 Clamping system

MV 8.1 Module clamping

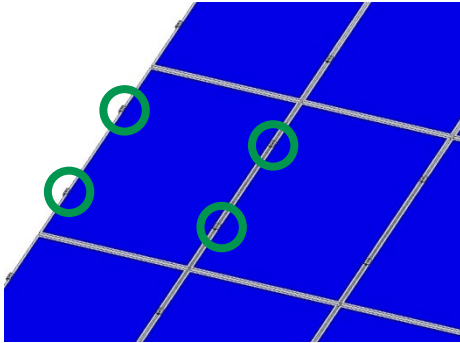

The modules must then be attached to the rails using end and middle clamps.

MV 8.2 Mounting the middle and end clamps

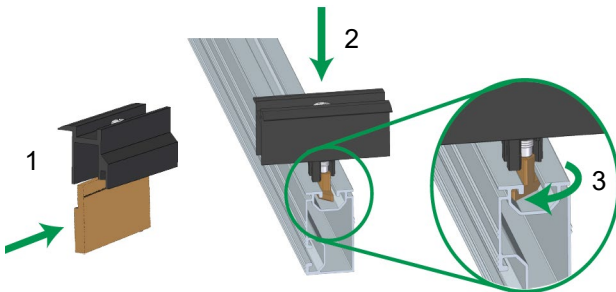

Fully assemble the end clamp, insert the spacer to do so (1) place the module clamp onto the N-rail and press it on (2) until the slot nut engages with an audible “click” in the groove channel (3).

NOTICE

During removal and re-installation rotate the slot nut back into the original position.

MV 8.3 Middle and end clamps space requirement

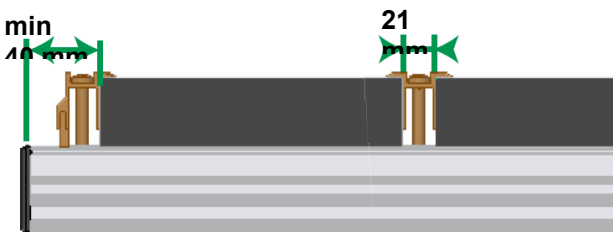

Ensure that the module clamps engage correctly in the rails, push the modules all the way to the stop, then tighten the module clamps.

The end clamp can be fitted with a distance of 40 mm to the rail end.

NOTICE

Module clamp tightening torque 15 Nm.

6 Warranty / product liability (exclusion)

In addition to the above-mentioned regulations and safety notices the applicable regulations and rules of technology must be observed by the installing specialist company.

The installer is responsible for the dimensioning of the mounting system.

The installer is responsible for the connection of the interfaces between the mounting system and the building. This also includes the tightness of the building envelope.

For flat roofs the roof insulation must be evaluated by the installer on site within his own responsibility regarding the material of the sealing layer, resistance, ageing, compatibility with other materials, overall condition of the roof insulation, need for a separating layer between the roof insulation and the mounting system. The required and necessary measures or precautions for the protection of the roof insulation for the mounting of the substructure of a PV system must be initiated by the installer with the aid of a specialist tradesman where necessary. BayWa r.e. Solar Energy Systems GmbH does not accept liability for faulty or inadequate measures and precautions for the protection of the roof insulation!

The installer must review the friction coefficient used in the calculation for the verification of the slip safety of PV systems on flat roofs on site. Friction coefficients determined on site can be taken into account by entering them in the Solar-Planit planning tool. BayWa r.e. Solar Energy Systems GmbH does not guarantee the correctness of the assumed values and is not liable for damage due to the use of incorrect values.

The specifications of the module, cable and inverter manufacturers must be observed. If these contradict the mounting instructions, always consult the BayWa r.e. Solar Energy Systems GmbH sales team before mounting the novotegra mounting system or – in the case of components not supplied by BayWa r.e. Solar Energy Systems GmbH – the manufacturer concerned.

During the preparation of the offers for novotegra by our sales staff the local conditions are not always sufficiently known, which is why changes to the offered quantities may result during installation. These changes relate mainly to the number of fasteners for the building envelope (for example roof hooks). In this case the additionally required components must always be installed in accordance with the dimensioning.

BayWa r.e. Solar Energy Systems GmbH is not liable for incorrect or incomplete data collection sheets. Error-free and fully completed data collection sheets are essential for correct dimensioning.

The information in the mounting instructions, the warranty terms and the information about the liability exclusion must be noted.



BayWa r.e. Solar Energy Systems GmbH

Eisenbahnstraße 150
D-72072 Tübingen
Tel. +49 7071 98987-0
Fax +49 7071 98987-10
solarenergysystems@baywa-re.com

www.baywa-re.com
solar-distribution.baywa-re.de
novotegra.de